

INSTRUCTIONS

For 2 - 1-3/8" (35mm) Doors
weighing up to
200 lbs (90 kgs) each.

1562 SERIES BYPASS POCKET DOOR FRAME

1562 MADE FOR 2" X 6" STUD WALLS

1562 SERIES SET NUMBERS AND SIZES

- 15622068 FOR 2-24" (609mm) X 80" (2,03m) Doors
- 15622668 FOR 2-30" (761mm) X 80" (2,03m) Doors
- 15623068 FOR 2-36" (913mm) X 80" (2,03m) Doors

CONVERGING DOORS REQUIRE TWO FRAMES AND THE 1556PLBG CONVERGING DOOR KIT.
1562 Frames for 7/0, 8/0, 9/0 Tall Doors available.

NOTE: Instructions are for a 80" (2,03m) door, if door is shorter, lower header and cut bottom ends of Split Studs. If taller, order taller 1562 Bypass Pocket Door Frame, i.e. 1562 7/0, 8/0, 9/0 frames.

- 1 CONSTRUCT ROUGH OPENING:** Header must be **SQUARE** and **PLUMB** with studs and **LEVEL**.
Minimum Height is Door Height 80" (2,03m) plus 5-3/4" (146mm).
Rough Opening Width is 3X Door Width plus 7/8" (22mm).

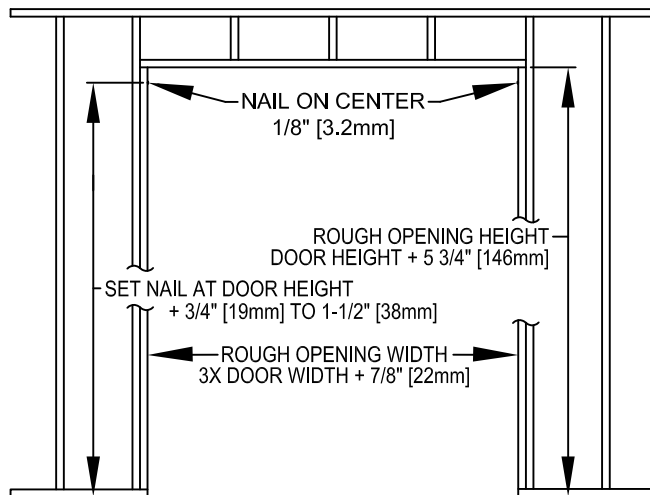

- 2 MEASURE** up from finished floor 80-3/4" (2.05m) or from sub-floor to 81-1/2" (2.07m). This will give 3/4" (19mm) to 1-1/2" (38mm) clearance under door. Mark each rough stud and drive a flat head nail on center, leaving 1/8" (3mm) protruding. (Frame header end brackets will rest on these nails).

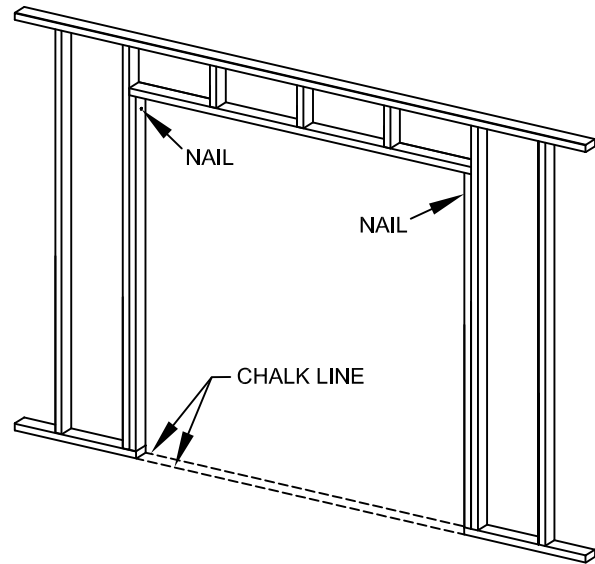

- 3 SNAP** a chalk line on floor even with side jambs.

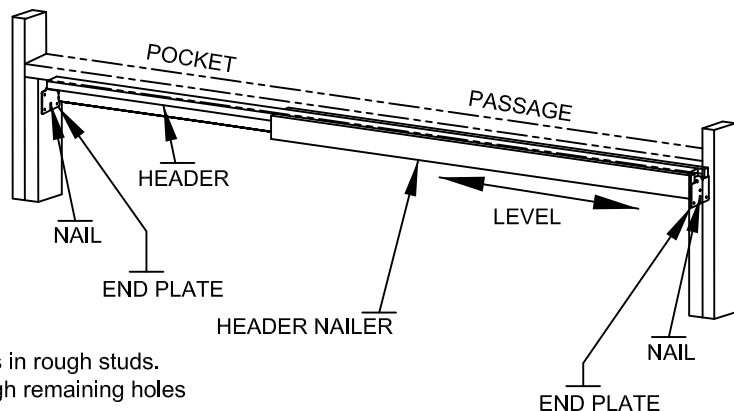

- 4 SLIP** slots in Frame Header End Plates over nails in rough studs. **LEVEL** HEADER. Set nails and drive nails through remaining holes in end plates.

5 SLIP fingers of Floor Plate into Split Studs as shown. Screw one pair of studs flush to side of Side Nailer Boards of Header and the other pair midway in the pocket area. Plumb Split Studs between Chalk lines and nail or screw to floor. (On masonry, use industrial adhesive or Tapcon fasteners.)

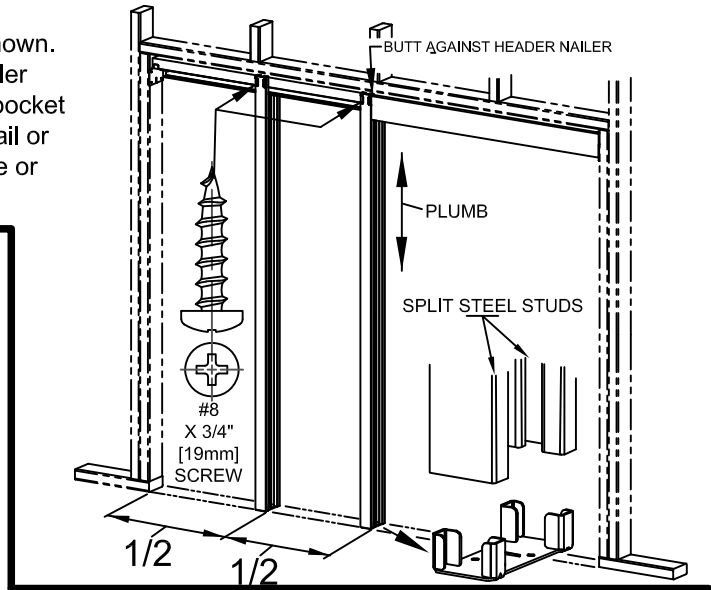
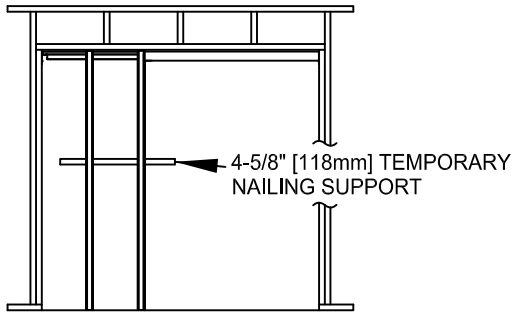

6 Apply desired wall material with 1" (25.4mm) X #6 Self drilling drywall screws. Use seven (7) screws per Split Steel Stud.

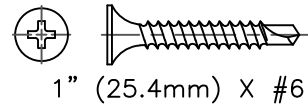

7 CUT a clear board 3/4" (19mm) X 3-1/8" (79mm) X Door Height. This will be attached to back of Guide Door to close pocket when opening is closed.



8 ATTACH Pocket Closer Board to back edge of Guide Door.

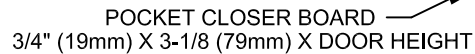

9 ROUTE 5/16" (8mm) X 1" (25mm) groove in the center of each doors bottom rail.

10 MORTISE ends of Lead Door and front edge of Guide Door for 2040 Groove Cover. 1-1/8" (28.6mm) wide X 1-1/2" (38mm) high X 3/32" (2.3mm) deep.

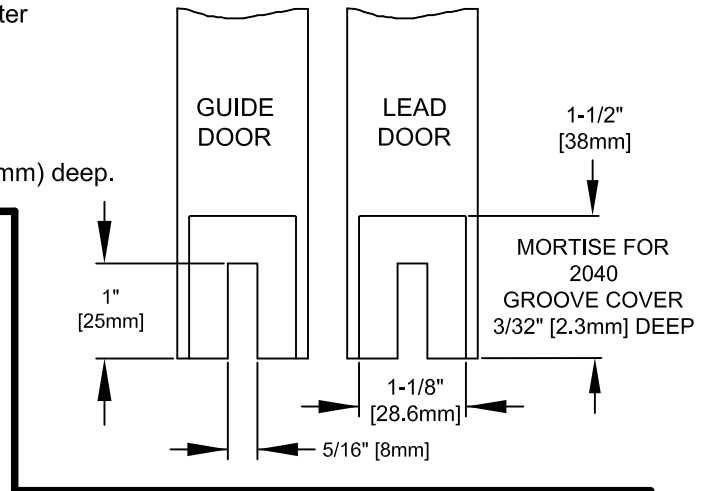
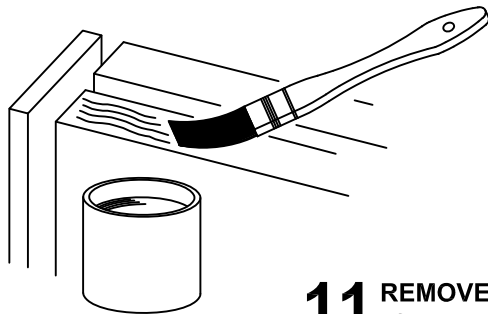

11 REMOVE Pocket Closer Board from Guide Door and seal all edges and faces of doors and pocket closer board with paint or sealer stain.

12 ATTACH 2032 Side Mount Guide to front face of Guide Door on same side as the Pocket Closer Board extends pass door face.

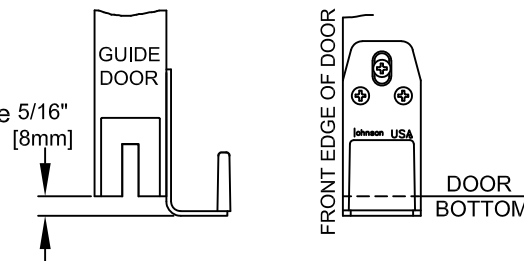

13 ATTACH 2054 Pull Catch to top front edge of Guide Door and top rear edge of Lead Door.

VIEW OF 2054 MULTI-DOOR PULL CATCH

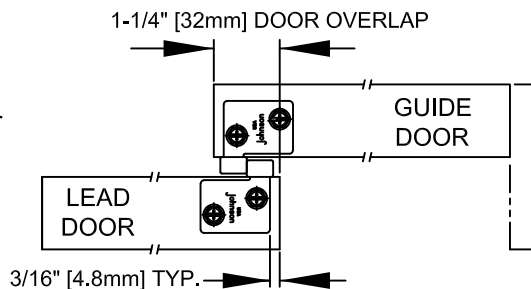

14 A/Attach door plate 1121 on top of door 2-3/4" (70mm) from each edge with lock tab on same side.

B/ Insert 1125 hangers into tracks alternating wheel wheel positions for even weight distribution.

C/ Mount Guide Door by first locating door plate 1121 under adjusting bolt of 1125 Hanger. Lift door and push bolt into door plate. Repeat with other hanger/door plate.

D/ Mount Lead Door next to Guide Door in same manner.

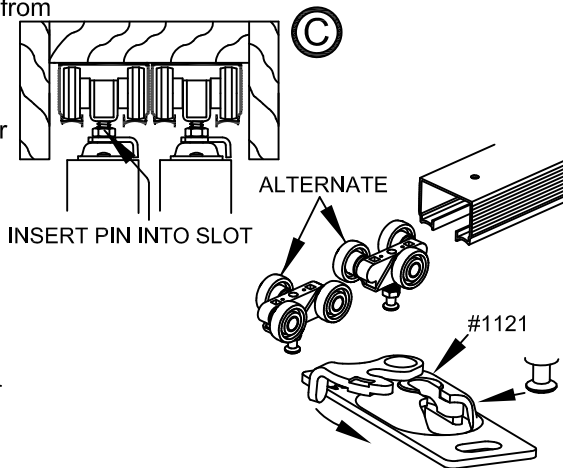

15 SLIDE Guide Door and Lead Door to strike Jamb rough stud and reattach Pocket Closer Board to Guide Door.

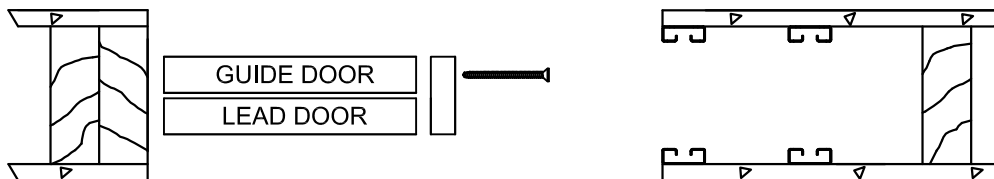

Note: Side Mount Guide must be in route groove of lead door.

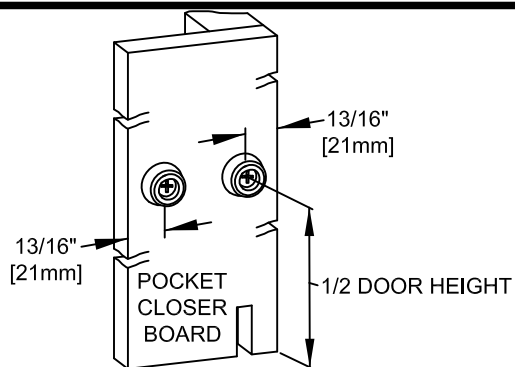

16 FASTEN 1513 Bumpers to back of Pocket Closer Board 1/2 the door height from floor. 13/16" (421m) from each edge.

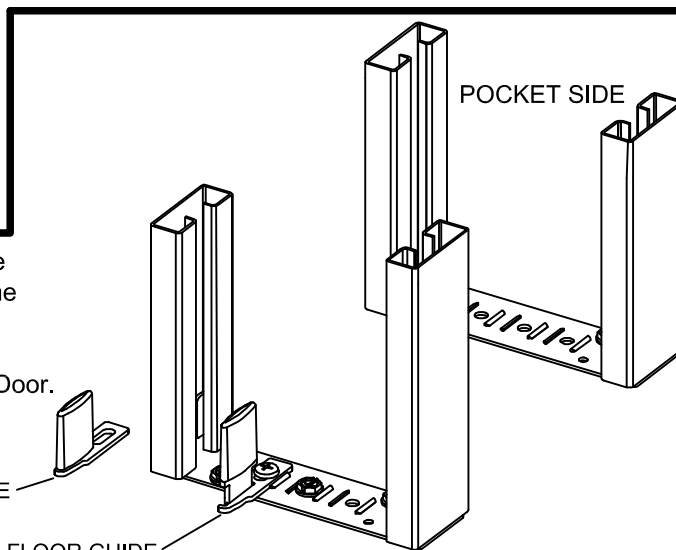

17 ATTACH 2041 Guide to floor bracket at edge of pocket opening. Use tall Guide when frame is attached to sub floor or Short Guide when attached to finished floor. Be sure to mount the 2041 on the side you want as the Guide Door.

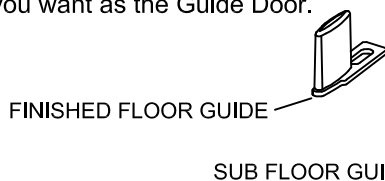

18 ATTACH 2040 Route Groove covers in mortised area, both sides of the Lead Door and only the front side of the Guide Door.

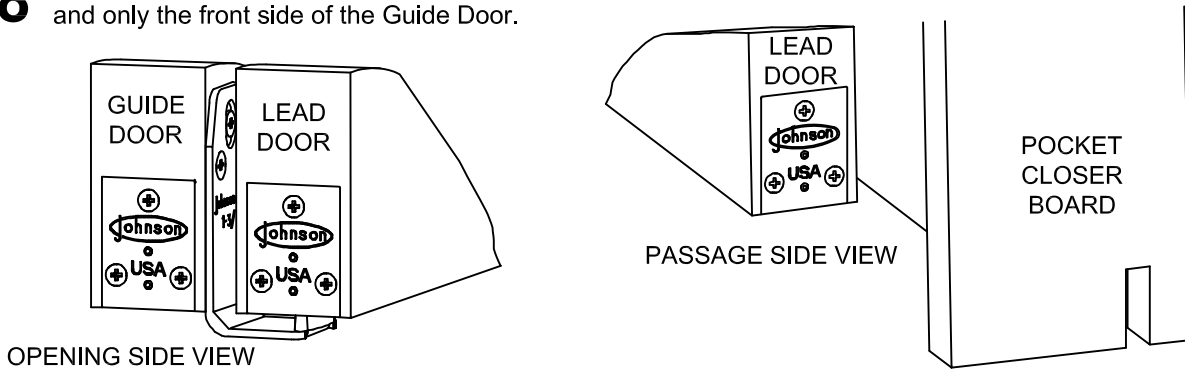

19 SLIDE 1155 Stop into Guide door track and adjust until the back edge of the Pocket Closer Board on the guide door is flush with the front edge of the steel wrapped studs.

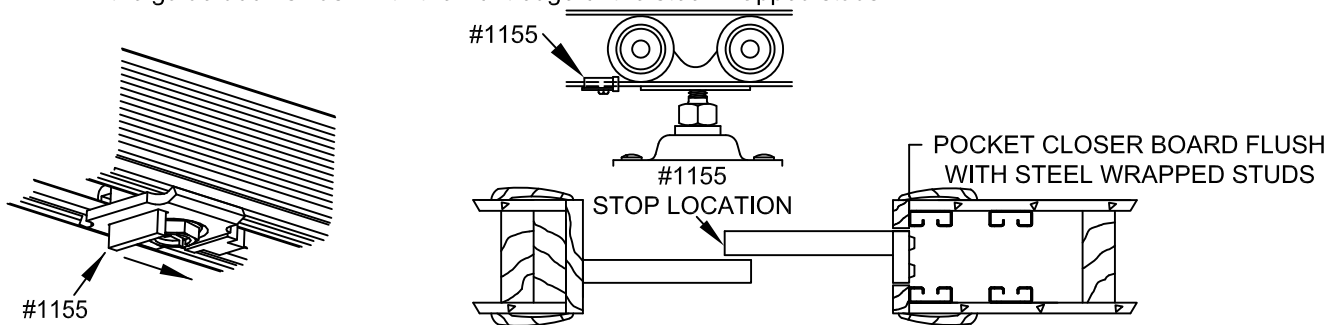

20 INSTALL finished jambs, split header and casing as shown. Fasten split header on 1121 lock lever side with screws for future door removal or adjustment. **DO NOT USE JAMBS WITH DADO'S.**

