



www.johnsonhardware.com

# INSTRUCTIONS

## POCKET DOOR FRAME 2711/2710 SERIES PREFABRICATED

For a 1-1/8" (28.6mm) to 1-3/8" (35mm) Thick Doors.

2711: 1020 Hanger 80lbs. (36kg) MAX.  
1025 Hanger 150lbs. (68kg) MAX.  
2710: 1120 Hanger 125lbs. (56kg) MAX.  
1125 Hanger 200lbs. (91kg) MAX.

For Converging Doors Use 1555PPK3 Converging Door Kit.

ORDER NO.	FOR 1-1/8" (28.6mm) OR 1-3/8" (35mm) THICK DOORS	ROUGH OPENING WIDTH & HEIGHT	SHIPPING DATA WEIGHT EACH
27112068	1 - 24" (609.9mm) X 80" (2032mm) DOOR	49-3/4" (1264mm) X 84-1/2" (2146mm)	23 lbs. (10.4kg)
27112468	1 - 28" (711.2mm) X 80" (2032mm) DOOR	57-3/4" (1467mm) X 84-1/2" (2146mm)	26 lbs. (11.8kg)
27112668	1 - 30" (762.0mm) X 80" (2032mm) DOOR	61-3/4" (1569mm) X 84-1/2" (2146mm)	27 lbs. (11.8kg)
27112868	1 - 32" (812.8mm) X 80" (2032mm) DOOR	65-3/4" (1670mm) X 84-1/2" (2146mm)	28 lbs. (11.8kg)
27113068	1 - 36" (914.4mm) X 80" (2032mm) DOOR	73-3/4" (1873mm) X 84-1/2" (2146mm)	31 lbs. (11.8kg)

Nail header into box frame, square with jamb. Place frame into rough opening and shim until jambs are perfectly vertical and track is absolutely level. (Door will not stay in position if track is not level.) Nail into opening.

Apply wall material BEFORE REMOVING POCKET SPACER BRACKETS. Make sure nails do not penetrate into pocket, or door will be damaged. Remove spacer. See note on sealing doors before installing bumper or installing door hanger plates.

Install bumper on back edge of door 40" (1m) from bottom of door.

Center hanger plates on top of door 2" (50mm) from each edge. Insert hanger pin into door plates and lock in position with clip. Slide door into pocket and apply finish stops (not furnished), allowing 3/16" (5mm) on each side of door to allow for any door warpage. Use flat head screws (provided) to fasten the split header on the side of the door where the clips are on. This will facilitate removing the door, if so desired, at a later date.

Fasten door guides at bottom and adjust for smooth operations.

**Note:** Wood doors **MUST** be sealed on all four edges and both faces **PRIOR** to installation. Maintain the recommended 3/16" (5mm) clearance between door and jamb stops. These precautions will ensure continued ease of door operations without problems of serious door warpage.

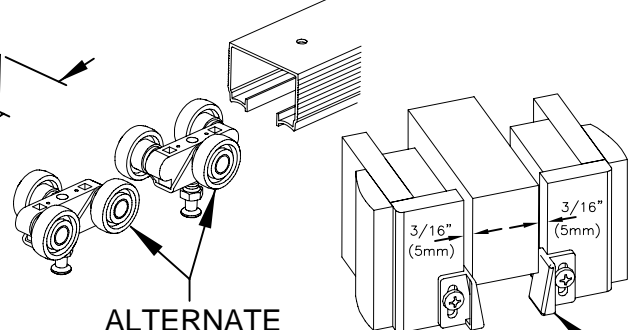
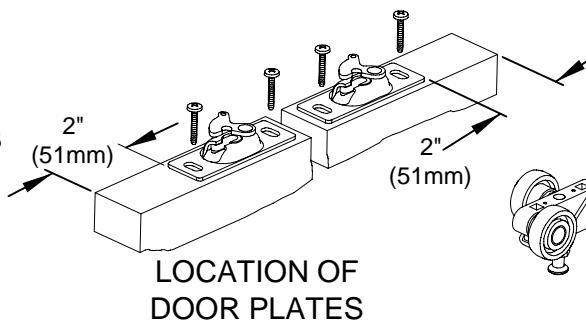
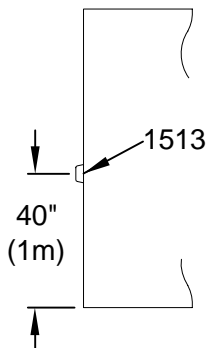
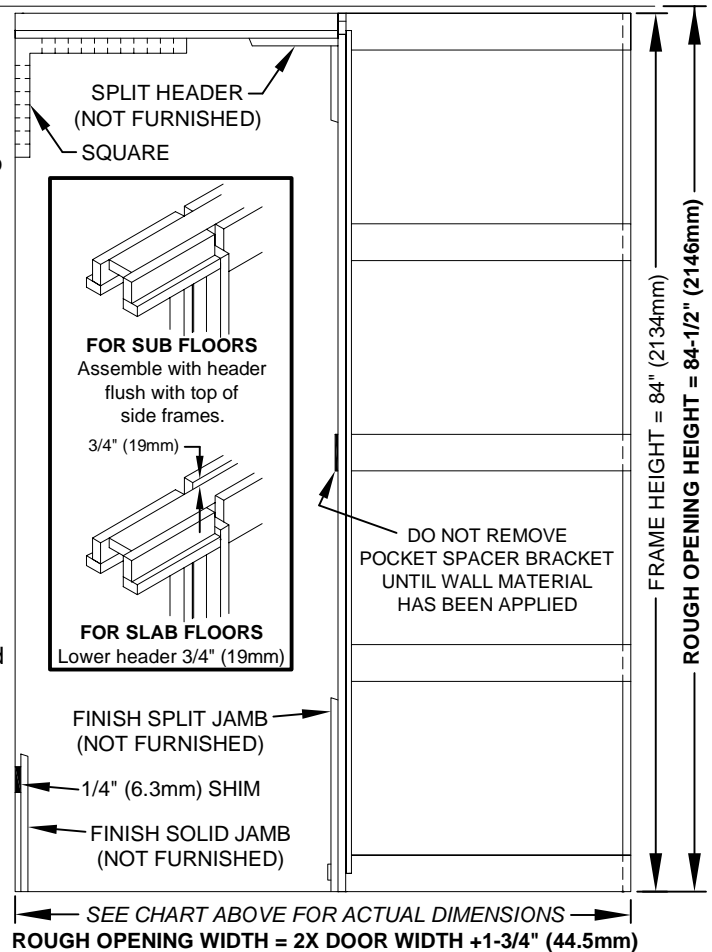
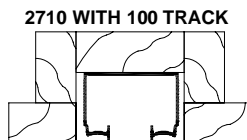
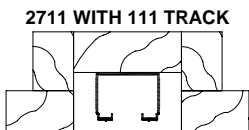

1550

# HOW TO APPLY TRIM AROUND A POCKET DOOR OPENING

Finish trim (solid and split jambs, head stops and casings) are not included as part of the 2711 FRAME package but are furnished by the customer. These instructions are shown as an aid to finishing your Pocket Door Frame and cover the peculiarities with its installation.

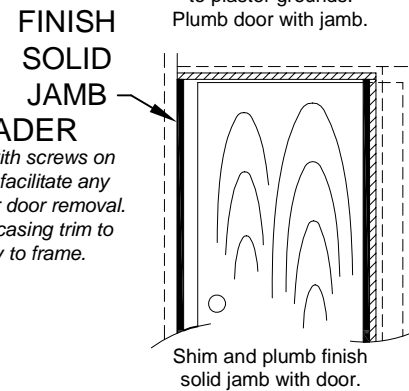
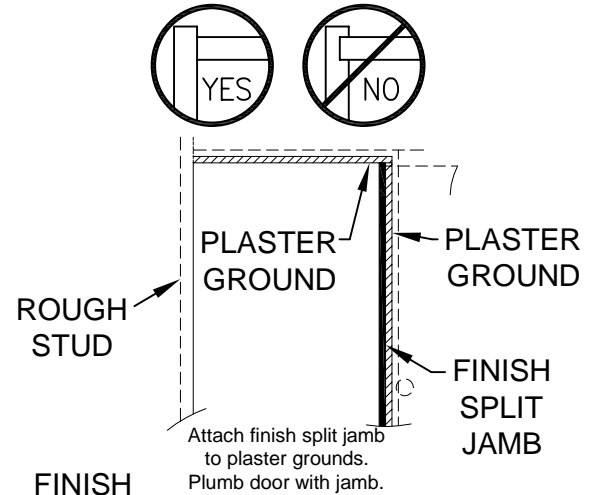
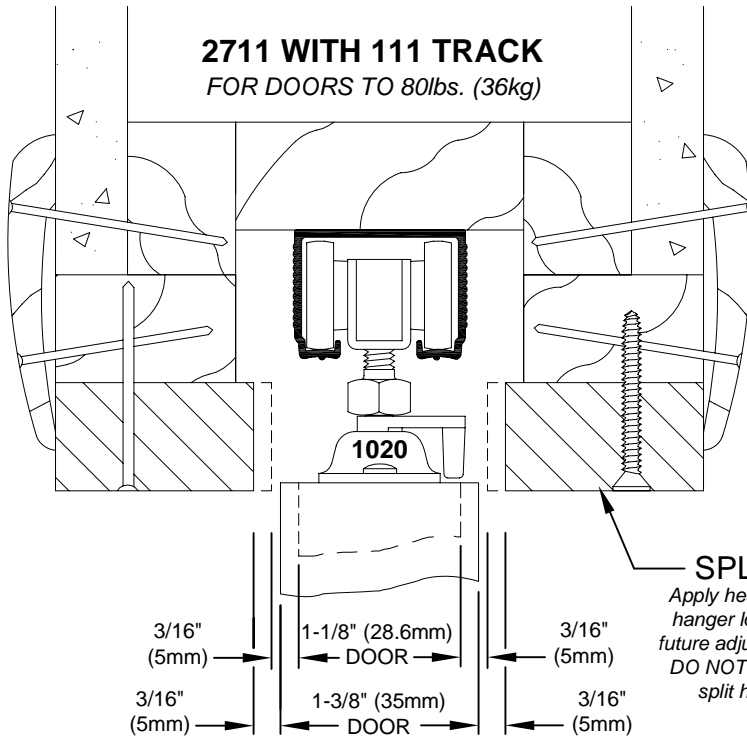

**SPLIT HEADER**  
Apply header trim with screws on hanger lock side to facilitate any future adjustments or door removal. DO NOT nail finish casing trim to split header, only to frame.

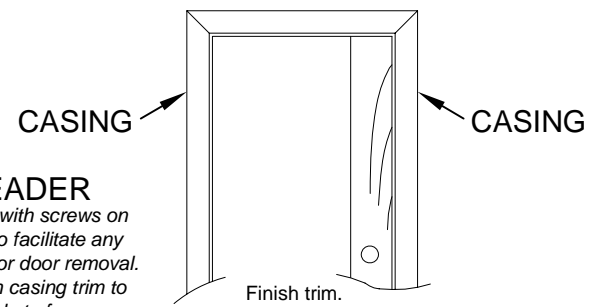
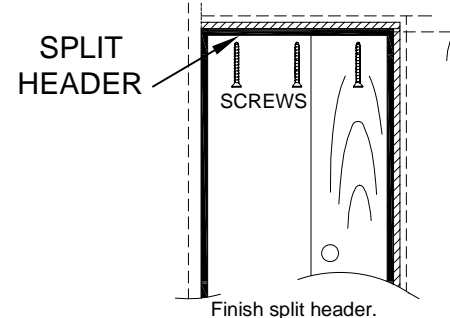
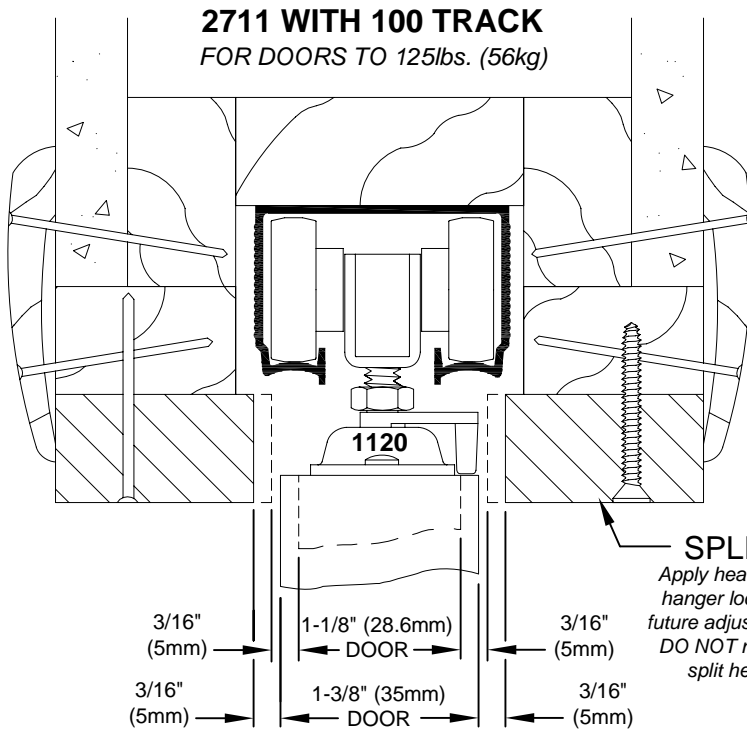

**SPLIT HEADER**  
Apply header trim with screws on hanger lock side to facilitate any future adjustments or door removal. DO NOT nail finish casing trim to split header, only to frame.

YOUR DEALER ALSO STOCKS AN ASSORTMENT OF PULLS AND THE JOHNSON POCKET DOOR LOCK TO COMPLETE YOUR INSTALLATION.