



www.johnsonhardware.com

INSTRUCTIONS

21 PULL / 134 PULL INSTRUCTION SHEET

USE 21 PULL WITH 1-3/8" (35mm) DOORS
USE 134 PULL WITH 1-3/4" (45mm) DOORS

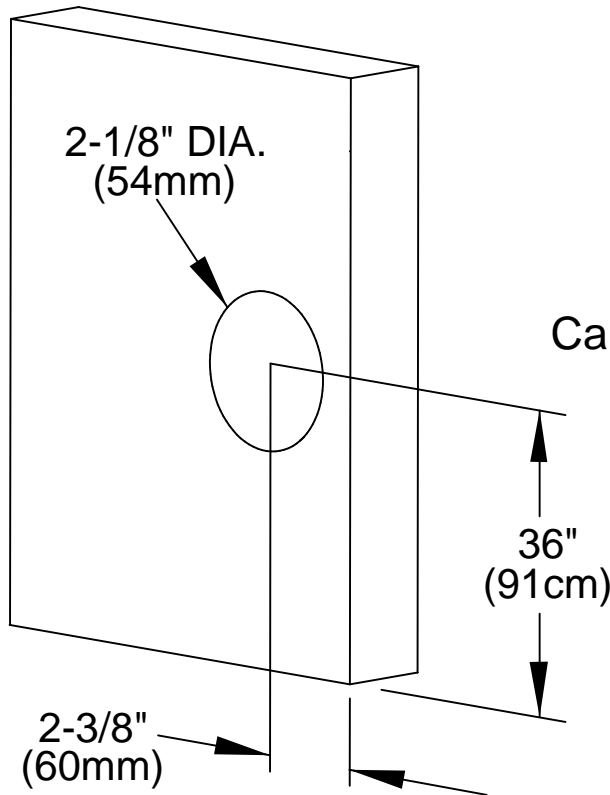

1) MARK THE DOOR as shown (or in a location that fits door style if other than flush door). Carefully bore 2-1/8" (54mm) Dia. hole thru door. Boring from both sides will prevent splintering of door skin. Hole must be in alignment, however.

2) INSERT PULL (with spacers attached) thru one side of door. Align other pull with spacer holes and assemble using 2 screws provided. Adjust for vertical squareness and tighten screws.

