



L.E. Johnson Products, Inc.
 2100 Sterling Ave.
 Elkhart, IN 46516
 Ph: (574) 293-5664
 Fax: (574) 294-4697
 info@johnsonhardware.com
 www.johnsonhardware.com



Engineered Excellence

1601

Full Access Bifold Hardware
 for 3/4" to 1 3/4" Thick Panels to 30 lbs. (14KG) per Panel

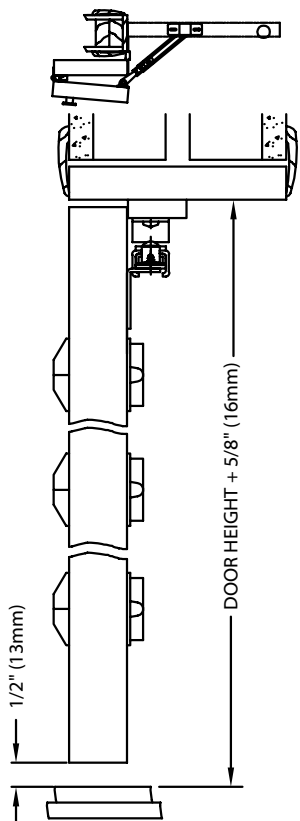

A unique folding door system that provides a 100% Clear Opening with doors folding 180 degrees and lying flat against the wall. Allows folding doors to be trimmed out like a swinging door. No track showing and no unsightly gaps.

Easy, fast mounting procedure saves time and can be prehung. Can also be used with standard mortise butt hinges to match other interior doors. The 1601 is ideal for locations where a full opening is required for removal of appliances for servicing, etc. Attractive woodtone finish on control arm and non-mortise jamb hinges blends with any decor. Available in standard packaged sets for two 12" to 18" doors, use two sets for four doors. Other sizes are available on special order, as are individual components in bulk form.

Ideal for Laundry Closets, Utilities, Pantries, Wardrobes, Wet Bar, etc.



1601 Exceptional Features

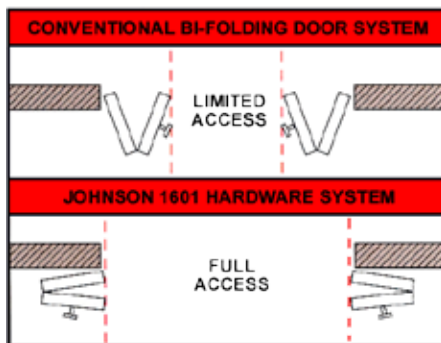

Full Access Opening

The 1601 is the only bifold hardware that allows doors to fold completely out of the opening.



1605 Hinge

Specially designed by Johnson. A two piece non-mortise hinge enabling doors to be removed by simply lifting off. Woodtone or white nylon options. Nylon bearing surfaces provide long wearing smooth action.

1703 Hinge

A shock-absorbing hinge, self-locating with its door spacing fingers, that "breathes" if any hinge binding or shock of door opening is encountered.

Complete Hardware Set 1601 Control Arm



1703 Hinge

1605 Non-Mortise Lift-Off Hinge



1513 Stop

33 Knob



1808 Door Aligner



Plus all screws and instructions



1601 Installation Overview

PREPARE OPENING CAREFULLY: MAKE SURE CORNERS ARE SQUARE, HEADER IS LEVEL AND JAMBS ARE STRAIGHT
PREPARE LAS PAERTURAS CON CUIDADO: ASEGURESE QUE LAS ESQUINAS ESTEN EN ESCUARDRA, EL ENCABEZADOR ESTE NIVELADO Y LAS JAMBAS ESTEN ALINEADAS.
PREPAREZ L'OUVERTURE AVEC PRECAUTION: ASSUREZ VOUS QUE LES COINS SONT A ANGLE DROIT, QUE LE GUIDE EST A NIVEAU QUE LES MONTANTS SONT DROITS.

