



www.johnsonhardware.com

INSTRUCTIONS

2075 SERIES GLASS DOOR HARDWARE

For 1/2" (12.5mm)
Tempered Glass Door Panel

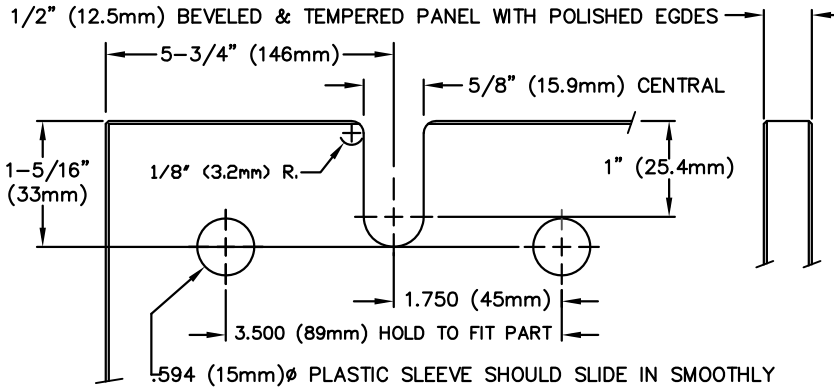

1 HAVE GLASS beveled, drilled and tempered per illustration.

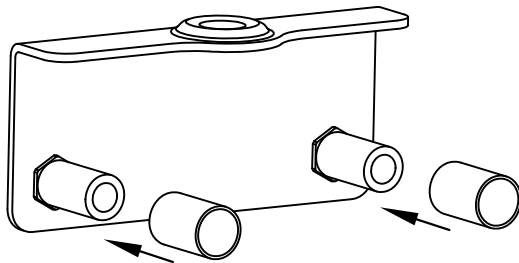

2 SLIDE PLASTIC SLEEVES over hanger post.

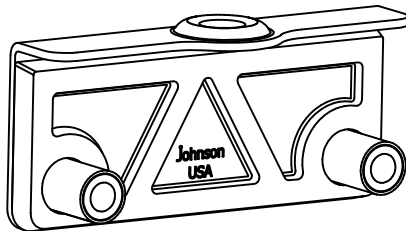

3 INSERT RUBBER PAD over post with smooth side facing metal plate.

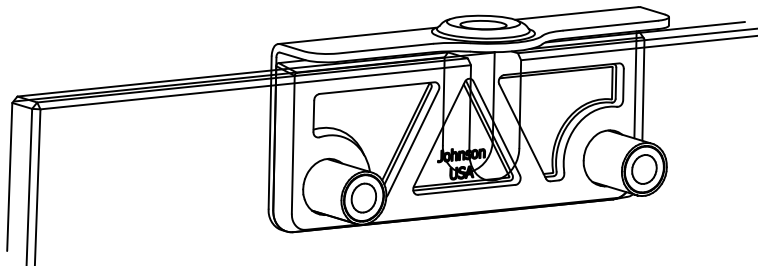

4 INSERT DOOR PLATE into holes drilled in door.

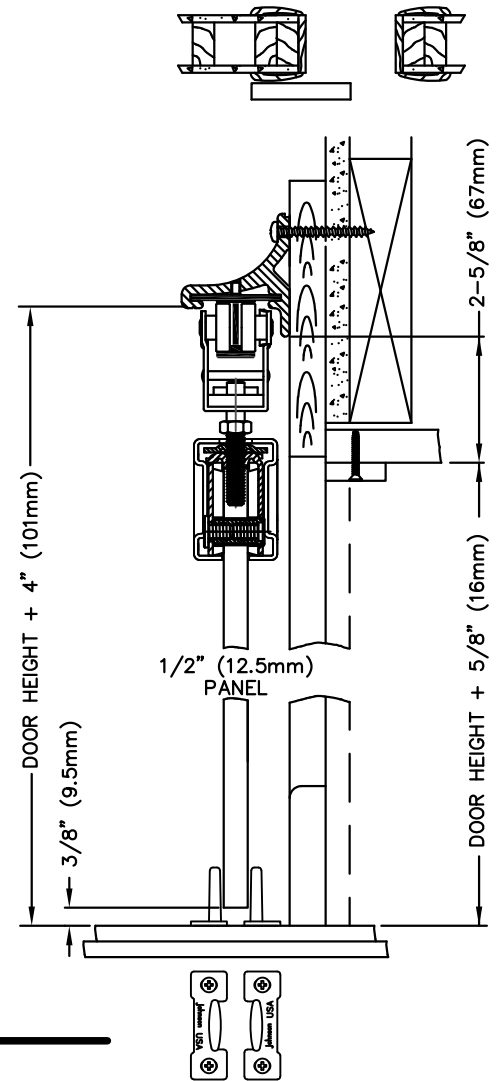

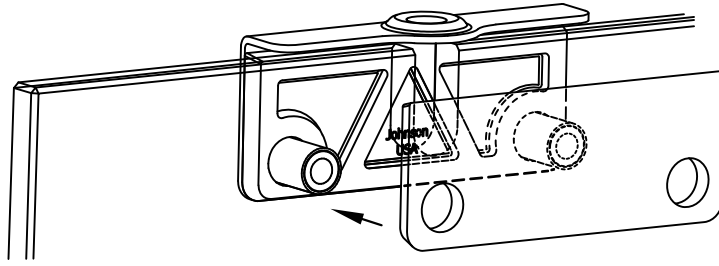

5 INSERT SECOND RUBBER pad on other side of glass, smooth side facing away from glass.

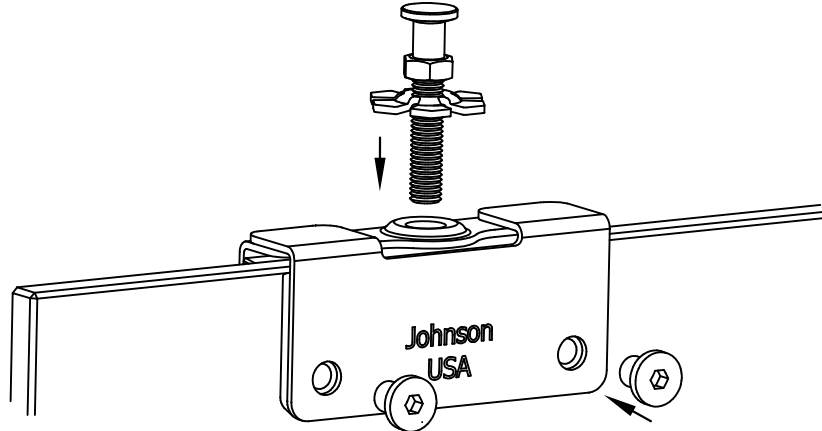

6 LAY OTHER HANGER PLATE against pad and thread 3/8" screws into metal post. Thread hex slotted Locknut onto adjusting bolt, then thread adjusting bolt into door plate.

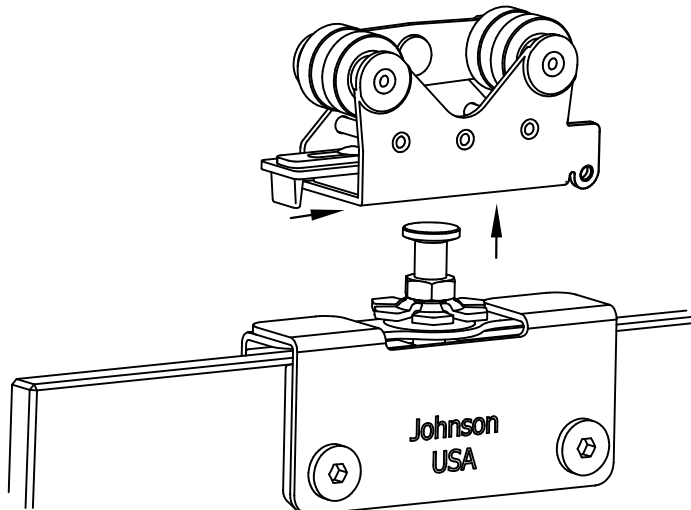

CLEAR ANY DEBRIS FROM TRACK AND WHEELS PRIOR TO HANGING DOOR.

7 HANG GLASS DOOR. Adjust Hanger then tighten locknut.

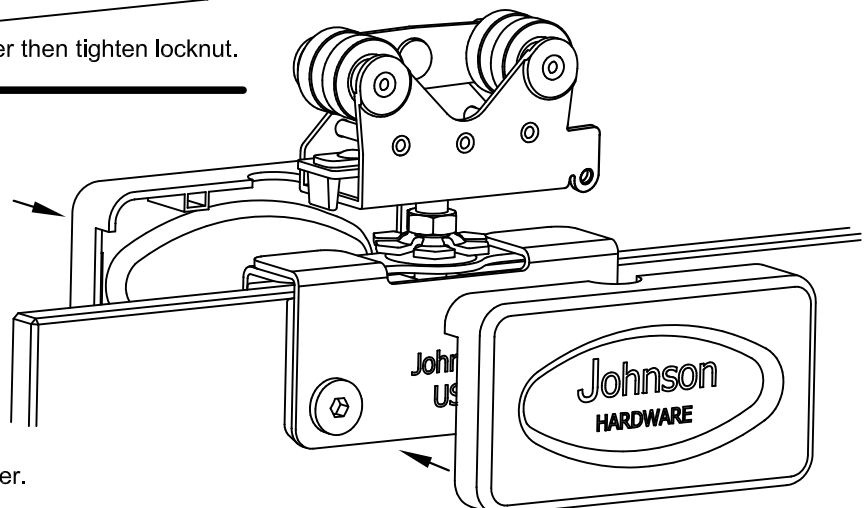

8 SNAP HANGER COVERS over Hanger.