



L.E. Johnson Products, Inc.
 2100 Sterling Ave.
 Elkhart, IN 46516
 Ph: (574) 293-5664
 Fax: (574) 294-4697
 info@johnsonhardware.com
 www.johnsonhardware.com



2000

Commercial Grade Pocket Door Frame
 for 1 1/8" to 1 3/4" Thick Door to 400 lbs. (2" x 4" Stud Wall)

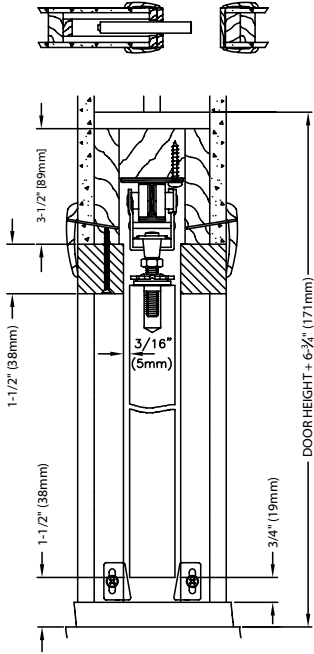

2000 Pocket Door Frame Features

QUICKSET FRAME HEADER

Prefabricated frame header section features preinstalled track and end brackets ready for fast installation into rough openings. Headers available in many standard door widths for direct installation or can be easily cut down and modified to accommodate smaller door widths. Frames available for doors from 2/6 X 6/8 up to 5/0 X 9/0. All 2/6 and 3/0 headers are marked for cutting to smaller, standard size widths. Available in 2/6, 3/0, 4/0, 5/0 widths and 6/8, 7/0, 8/0, 9/0 heights.

200 SERIES TRACK

Heavy-duty precision extruded aluminum jump-proof "I" beam track design for heavy doors and smooth operation.

HEAVY-DUTY 4-WHEEL DOOR HANGERS

Ball-bearing wheels for smooth low-resistance rolling. Hanger features unique "rocker" design that ensures constant 4-wheel track contact and equal weight distribution. "Flip-of-a-clip" separates wheels from the door plate for easy door installation/removal. All steel hardware parts are zinc plated for corrosion resistance and quality appearance.

SELF ADJUSTING FLOOR BRACKETS

Long vertical fingers slide into split studs allowing for floor settling without disturbing horizontal alignment of header and track. Anchor can be nailed, screwed or cemented to floor. **NOTE: 1 3/4" doors require included 1575 Adaptor Kit.*

STRONG STIFFENERS

Split jamb and stud uprights have full steel sides and backs to provide maximum rigidity for wall material and restricts nails from penetration into pocket. Slots allow room for easy nailing of trim stops.

TESTED QUALITY

Johnson Pocket Door Frames are regularly tested to ANSI standards.



Shown with optional
 2041 Hidden Guide



See online at: www.johnsonhardware.com/2000.htm



Cutting Instructions-Johnson Hardware Pocket Door Frame Header

2000 Johnson Pocket Door Frames are marked for cutting to shorter lengths. See cutting instructions below.

- Remove Adjustable End Bracket.
 - 2/10 = 34" [86cm]
 - 2/8 = 32" [81cm]
 - 2/6 = 30" [76cm]
 - 2/4 = 28" [71cm]
 - 2/2 = 26" [66cm]
 - 2/0 = 24" [61cm]

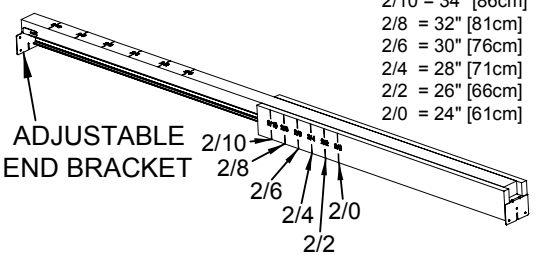

- Cut through WOOD part of header only, on desired door size marking.

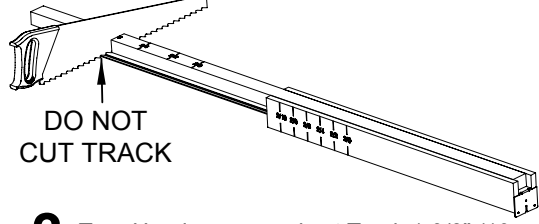

- Turn Header over and cut Track 1-3/8" (19mm) shorter than wood Header.

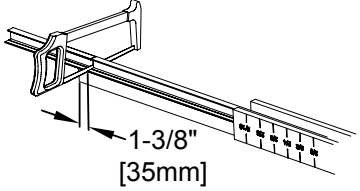

- Replace Adjustable End Bracket on new cut end of header.

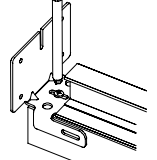

- Turn Header on side and cut 3/4" (19mm) Head Trim Board ONLY at proper mark. Remove cut off end and discard.

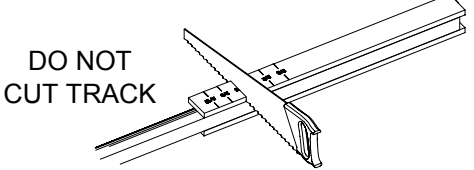

- Turn Header and cut off other side.

Installation Instructions

Johnson Hardware Pocket Door Frame Header

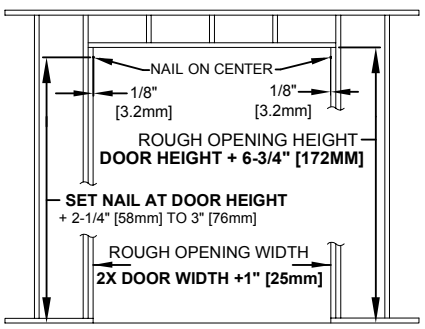

- Header must be SQUARE and PLUMB with studs and LEVEL. Mark each side jamb and drive a flat head nail on centerline, leaving 1/8" (3.2mm) protruding. (Frame header end plates will rest on these nails.)

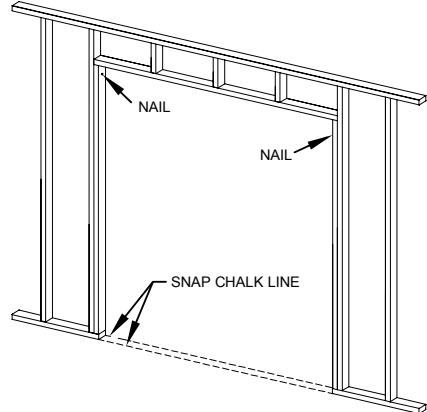

- Snap two chalk lines on floor even with side jambs as shown.

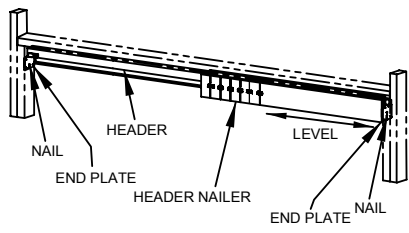

- Slip slots in Frame Header End Plates over nails in side jambs.

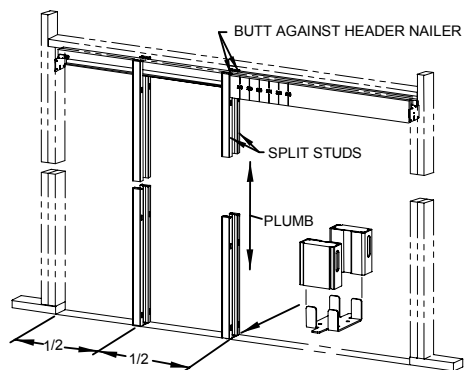

- Slip fingers on floor Plates into the reinforcing strips of Split Studs as shown. Butt Split Studs against header nailer strips and nail in place.

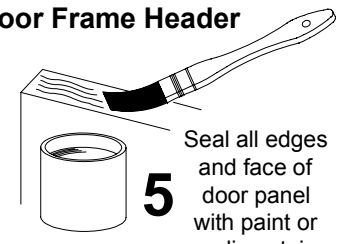

5

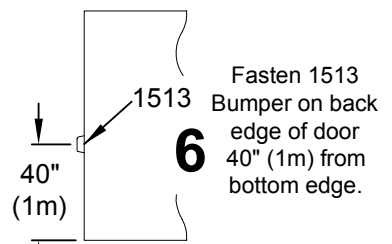

6

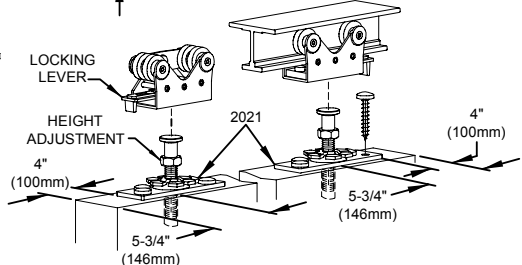

- Attach door plate 2021 by drilling a hole 1/2" (12.5mm) Dia. X 1-1/2" (38mm) deep on top of door 5-3/4" (146mm) from each edge. Insert hangers 2020 into track. Mount door by locating the adjusting bolt of door plate 2021 under hanger 2020 and lift door until bolt will slide into seat of hanger 2020.

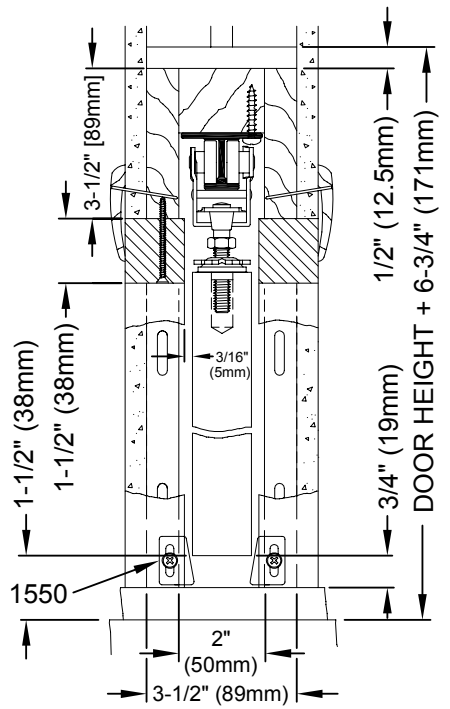

- Fasten #1550 Guides on finished split jambs at door bottom so door is held in center of opening without binding.