

SLIDING DOORS

**Fifteen
Minute*
Fix-It
Guide for
Broken
Closet
Doors**

FOLDING DOORS

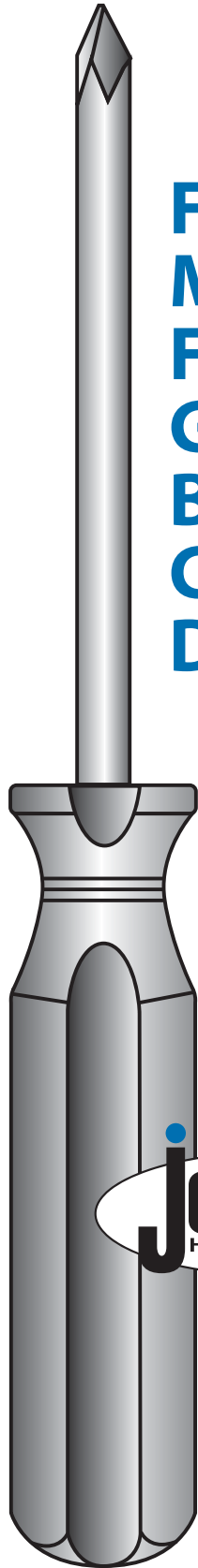

Johnson
HARDWARE®

Engineered Excellence

***or less**



Engineered Excellence

Johnson's universal repair parts help you conquer broken closet doors! Johnson Hardware's universal folding and sliding door repair parts will replace nearly every brand of broken hardware including many which are obsolete. No more exhausting searches for the matching part ... no more replacing the entire installation when you can't find the right hardware. Johnson makes it easy ... step-by-step. The only tools you'll need are a screwdriver (Phillips head), a hammer and, perhaps, a drill with a 15/32" bit.

Replacing Knobs and Pulls

Johnson Hardware offers a wide assortment of knobs and pulls to finish off your folding and sliding door installations or replace those which are broken.

Johnson's universal repair parts for folding and sliding doors have everything you'll need to have closet doors that work perfectly. For other helpful hints and quality door hardware, ask your hardware retailer about Johnson's do-it-yourself booklets and complete hardware kits for folding doors, sliding doors, pocket doors and 100% access folding doors! Johnson Hardware – the do-it-yourselfer's problem solvers!

Folding (Bifold) Doors

Folding doors can have one (either right or left hand fold) or two doors made up of two panels hinged together. The doors swing on pivots positioned at the top and bottom of the door panel next to the jamb (door frame).

In most cases, the pivots support the weight of the door while the track acts as a guide for the traveling door panel. The top guide on the unpivoted door panel keeps that section of the door in place.

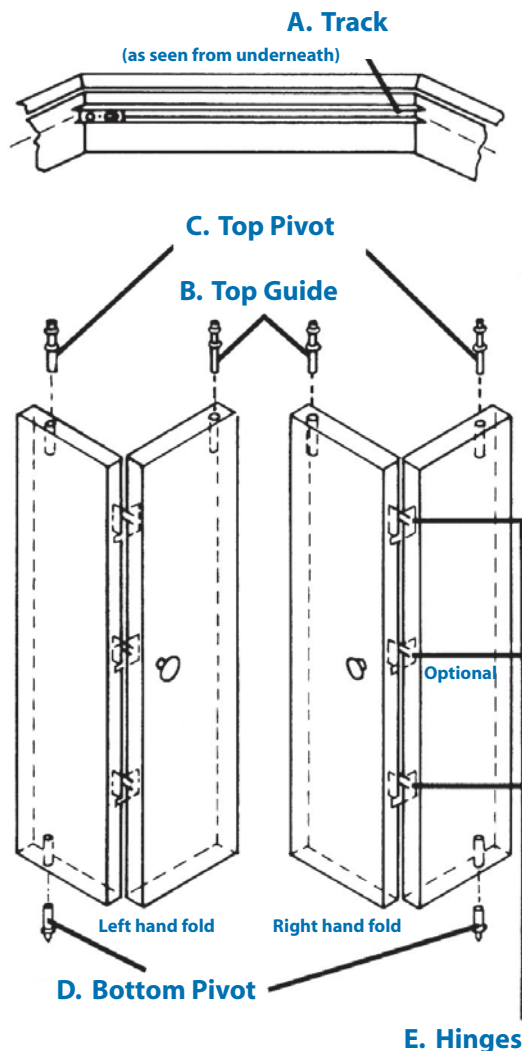

FOLDING DOORS

There are five areas where trouble can develop in a folding door installation.

A bent or damaged track (A) is the one component of a folding door installation that cannot be repaired. When the track is damaged, the entire installation should be replaced. Johnson's 1700 track and hardware is an ideal replacement set for the do-it-yourselfer. Ask your dealer for a copy of Johnson's "What Every Unhandyman Should Know About Balking Folding Doors".

When the trouble is a broken part, the affected door must be removed. Simply lift the door from the bottom, pushing up on the panel nearest the jamb until the bottom pivot is clear of the jamb bracket. (You may have to manually unscrew the bottom pivot until it clears.) Next pull the bottom of the panel outward (towards you) until the top of the door comes free from the track.

To replace the top guide (B), remove the old one from the door and, if necessary, enlarge the hole to 15/32". Compare the old guide to the parts in the package and select the top hat (guide) that most nearly matches the track. (See package back for full size illustrations.) Firmly press the selected top into the new guide post and discard the unused tops. Tap the new guide (with proper top) into the 15/32" hole in the top of the door.

A sprung or broken top pivot (C) can be replaced with the post found in the top guide package. Merely remove the old pivot (making sure the hole is 15/32") and replace with Johnson's top guide post.

If the trouble is a sprung or broken bottom pivot or jamb bracket (D), remove the old pivot from the door and press in the new 1807 pivot. (Again, make sure the hole is 15/32".) Next replace the jamb bracket (refer to illustration on package back) and rehang the door. Be sure to adjust the bottom pivot so the top of the door is approximately 3/8" from track for best operation.

If hinges (E) become bent, broken, or encrusted with paint or other foreign matter, the smooth movement of the door will be hampered. Hinges can be easily replaced and will restore your doors to their original condition. Your dealer can help you select the correct hinge.

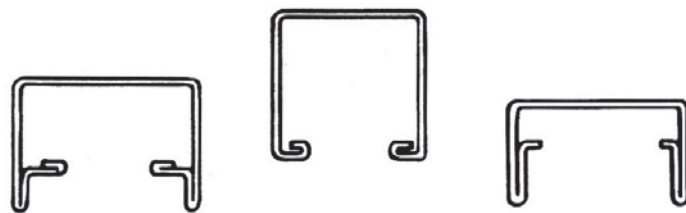

A. Various track types



B. Top guide and top hat

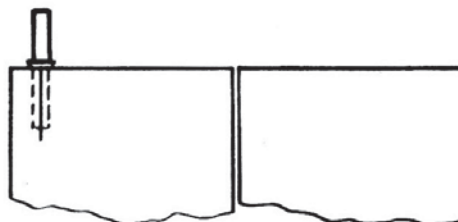

C. Top pivot

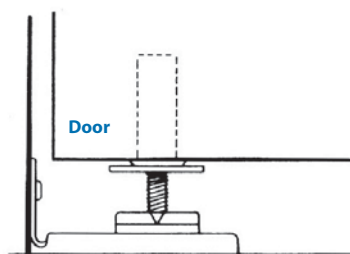

D. Bottom pivot and jamb bracket

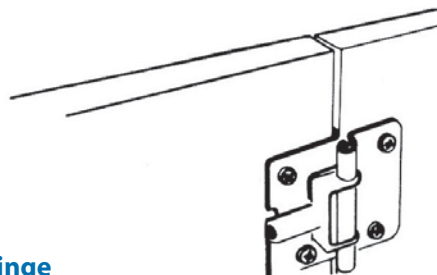

E. Hinge

There are five areas where trouble can develop in a sliding door installation.

If the track is damaged in any way, the old hardware and track should be replaced. Johnson's 2200 series sliding door hardware will fit most openings and is easy to install. Ask for Johnson's booklet, "Installing Sliding Door Hardware," for helpful hints. Johnson also manufactures hardware for odd size openings.

To replace a broken hanger, the affected sliding door panel should be removed from the track. Removal is simple. First remove the floor guide (C). Next tilt the front panel outward and lift off track. (Diagram II) It is always necessary to take off the front door first and the rear door second. When remounting, the rear door must be put in place first.

Now determine the track shape. (Diagram I) It will be either a crown (convex) track or V-track. If you have a V-track, you must determine the wheel diameter. It will be either 3/4" (small) or 7/8" (large). (Diagram III) Finally determine the offset size (Diagram IV)

Examine the old hanger. Most hangers will have either a 1/16" offset or a 3/8" offset.

Since the crown track has only one wheel size, all you need to know is which hanger offset (3/8" or 1/16") you have to replace. Once you have determined track shape, wheel size (if applicable) and offset, it will be easy to choose the correct part from Johnson's universal repair parts assortment. If you have any questions, you can take the broken hanger to your Johnson Hardware dealer.

Always replace both hangers on a sliding door panel. Simple-to-follow instructions are on the package back to help you select the proper hanger. With the new hangers, rehang door and reinstall the floor guide (C). (Diagram V) If your floor guide is broken or bent, now is a good time to replace it.

Guides are fastened after the doors are firmly in place on the track. Complete installation instructions are found on the back of the Johnson's #2135PPK1 Floor Guide package. If you have carpet, consider using Johnson's #2136PPK1 Carpet Riser.

A door bumper (E) (Diagram VI) is a convenient plastic and rubber stop that fastens to the back of the front sliding panel. It prevents the rear door from opening beyond the door pull and eliminates pinches fingers. A broken door stop is easily replaced and, if your installation did not originally feature one, they are easy to install. Complete instructions will be found on the package back. (Johnson part #2155PPK1)



I. Crown (convex) track

V-track

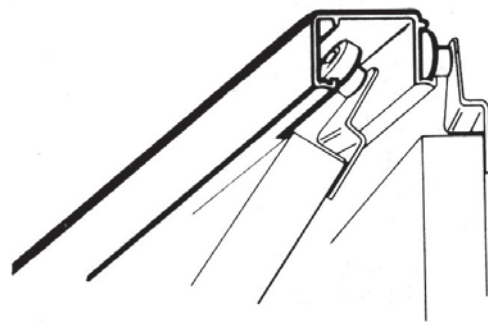

II. Sliding door panel removal

NOTE: Hangers should be positioned 1" from end of door.

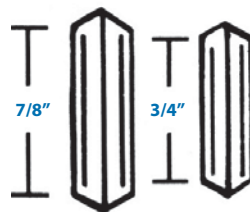

III. Wheel sizes

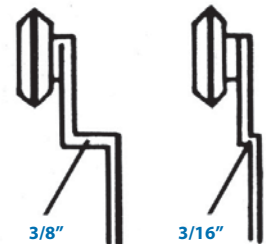

IV. Offset sizes

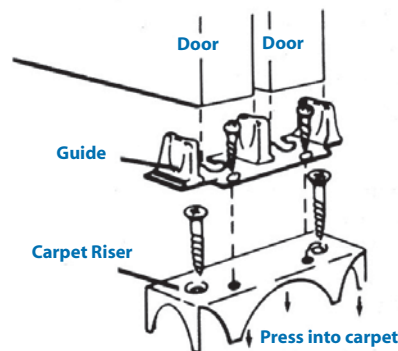

V. Floor guide and carpet riser

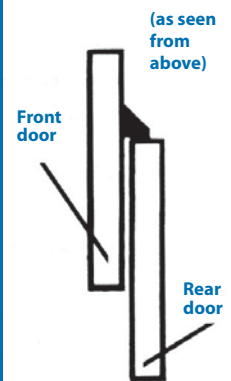

VI. Bumper stop

Sliding (Bypass) Doors*

*See inside front cover.

Sliding doors are made up of panels which hang from a top track and are kept in place by a center guide that is fastened to the floor midway between the two sides of the door frame.

The only tool you'll need is a Phillips head screwdriver.

B. Hangers – These are attached to the front door panel and roll back and forth in the track.

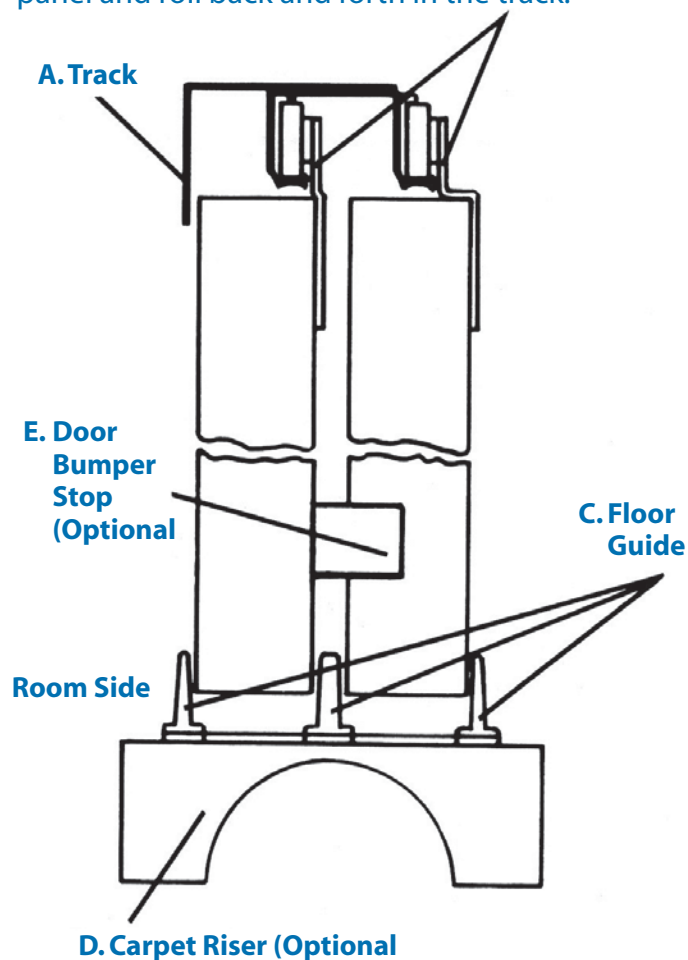

L.E. Johnson Products, Inc.
2100 Sterling Avenue
Elkhart, IN 46516
Phone: 574/293-5664
Fax: 574/294-4697

www.johnsonhardware.com