



www.johnsonhardware.com

# INSTRUCTIONS

## 2222 SERIES SLIDING DOOR HARDWARE

For a 1-3/8" (35mm) Doors  
UP to 50 lbs. (18kg)  
(single wheel hanger).  
UP to 75 lbs (28kg)  
(double wheel hanger).

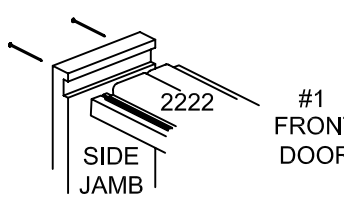
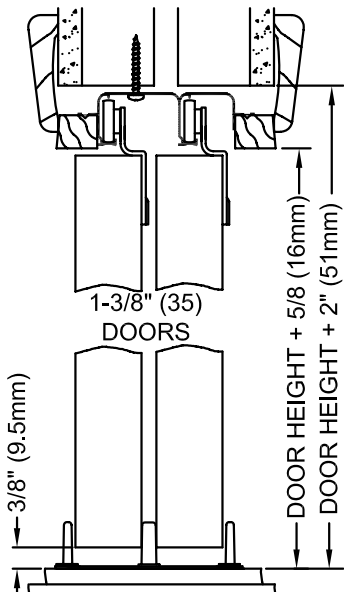
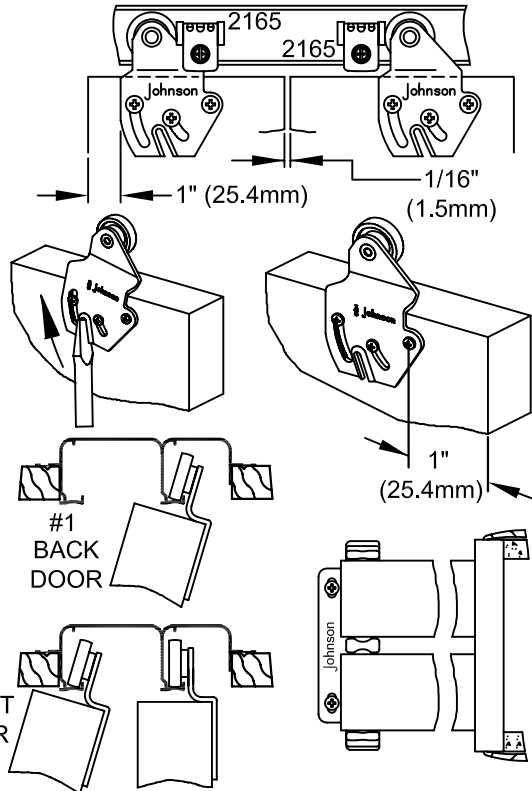
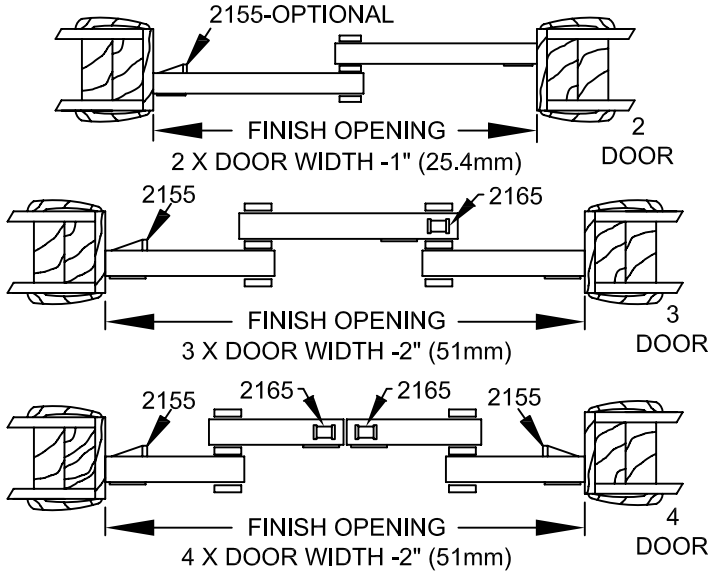

**PREPARE OPENING.** Make sure rough opening is square and straight. Stated dimensions allow for shimming of finished jamb. Place header ends into dado of side jambs and nail in place. Place assembled frame into rough opening and shim in place, being certain that FRONT edge is on room side (see diagram). Fasten track to rough header with screw through hole in center of track. Do not overtighten. Opening may be finished with trim at this time.

**DOORS.** Finish doors ON ALL SURFACES before mounting hangers. This seals against moisture which causes warping. Fasten hangers on BACK side of doors, 1" from each edge. Temporarily raise hangers to highest position for easier hanging. Screws must be placed at top end of slots when hanger is in the lowest position. Holes for pulls may be drilled at this time or after doors are hung. Holes must be large enough to avoid splitting, but snug enough to hold pull in place (if holes are too large, wrap tape around pull). Hang back door first. Tilt top of door back and place oth hangers on rear rail of track. Let hang free. Repeat with front door on front rail. Adjust hangers to raise doors as high as possible, keeping door edges square with side jambs.

**DOOR GUIDE.** Push doors to one side of opening. Place Guide between doors, flush with edge Plumb doors with door casing and fasten Guide in place.

OPTIONAL CARPET RISER #2136 (not shown)  
if carpet riser is used cut 5/8" (16mm) from bottom of door.

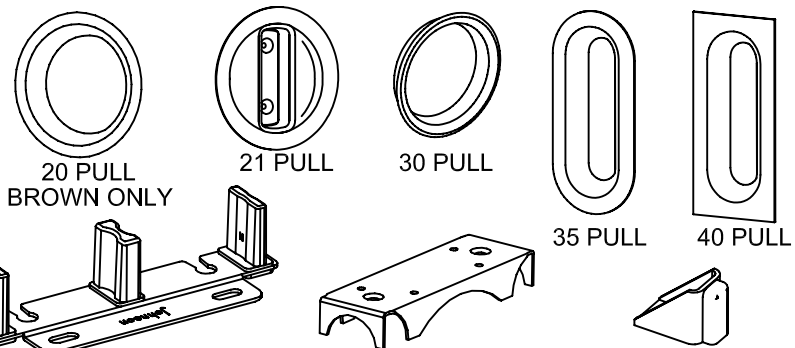
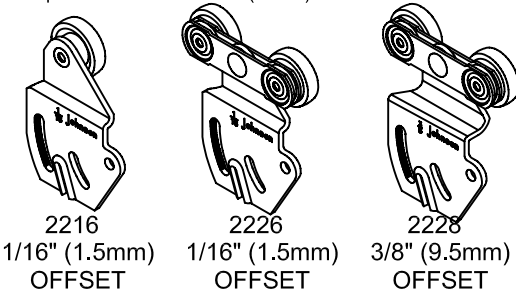

FOR 1-1/8" (29mm) DOORS  
USE (2)-2216 OR (2)-2226 ON BACK DOOR

2118 GUIDE FOR  
1-1/8" (28.5mm) DOORS

2136 CARPET RISER

2155 BUMPER STOP